

ADVANCED
Building Products Inc.
2026 CATALOG

**Allowing Moisture to
DRAIN, Not Remain®**

RESIDENTIAL · MULTI-FAMILY · COMMERCIAL

AdvancedBuildingProducts.com

Table of Contents

Watch our Company Video



Pages 4-5



Page 19



Page 18



Pages 14-15



Page 5



Page 10



Page 11

WATAIRVENT® FURRING STRIP

Pages 6-7



MORTAIRVENT® CW Masonry Cavity Wall Drainage and Ventilation

Page 8

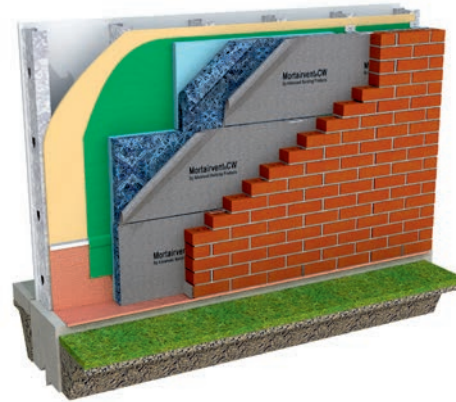

MORTAR BREAK® DT Mortar Deflection System

Page 9



R-VENT® Roof Ventilation Mat

Pages 12-13

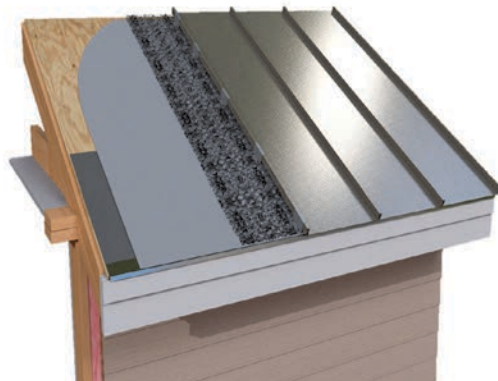

GROUNDGUARD® Root Reinforcing Mat

Pages 16-17

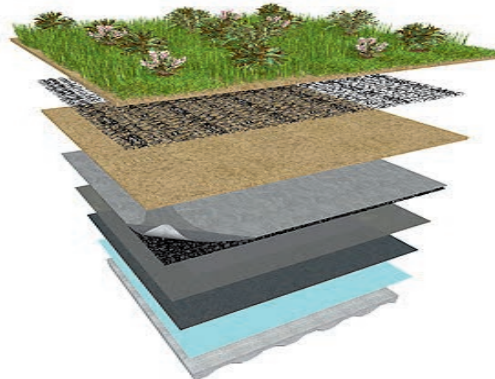

INSULAIR® Rafter Vent Mat

Page 20



The Importance of Rainscreen Technology

When building exterior walls with stone, stucco, brick, wood, or fiber cement siding, it is important to use an effective rainscreen system that will provide a means for drainage and ventilation. Moisture will find its way into these wall systems by way of cracked mortar joints and gaps or cracks in the surface material and become trapped in the wall system, creating the perfect environment for toxic mold growth and possible structural failure. Mortairvent® is a drainage and ventilation system specifically designed for use with most exterior siding materials.

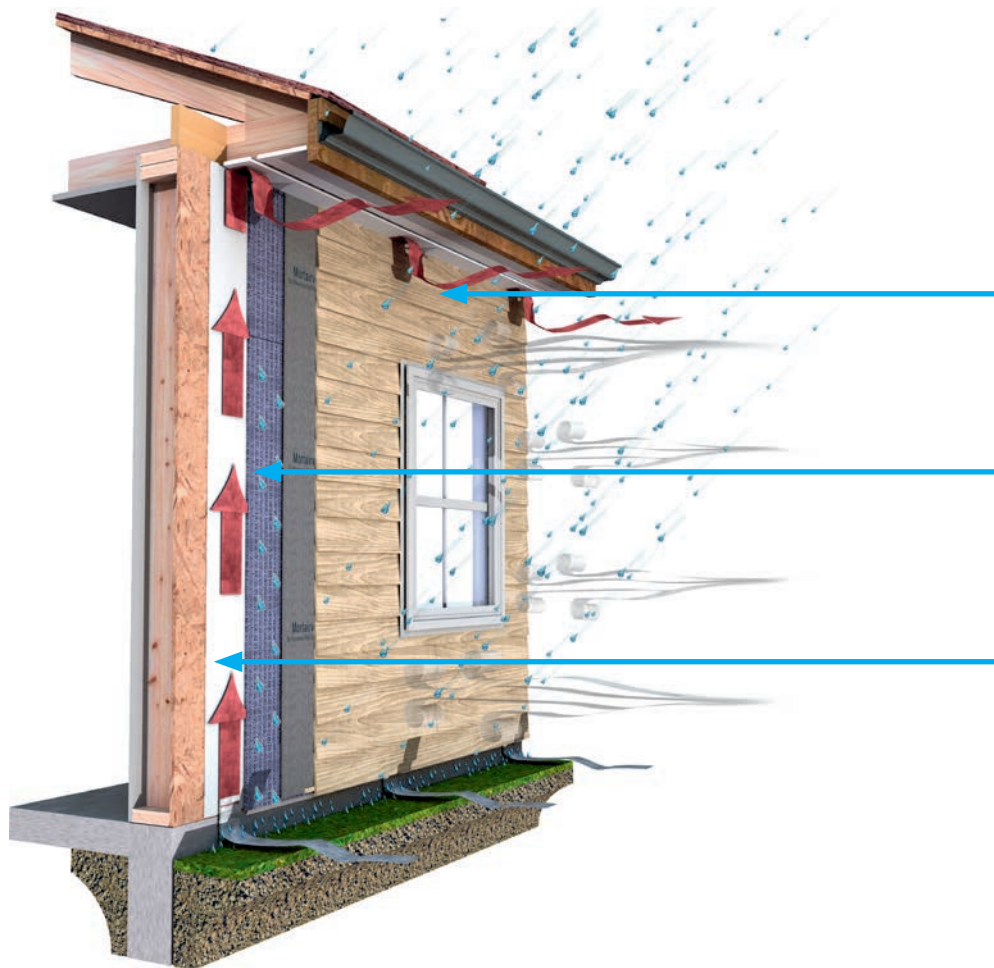

Wind-swept rain saturates the exterior cladding. Capillary action draws the moisture further into the wall assembly.

Moisture passes through the heat-bonded fabric filter and drains down the airspace created by the entangled net and out of the wall via a weep screed.

Residual water vapor is removed by convective air currents within the ventilated airspace created by the rainscreen. The airflow within this space also accelerates the drying of both the exterior and interior surface of the cladding.

Common Rainscreen Questions

What is rainscreen?

A rainscreen is an assembly, not a product, applied to an exterior wall which consists of, at minimum, an inner layer, an outer layer, and a cavity between them sufficient for the passive removal of liquid water and water vapor.

Why should walls be built with rainscreen technology?

- 90% of all wall failures are caused by moisture-related issues.
- 45% of all buildings currently have moisture-related issues, yet the building owner is unaware.
- Over 80% of all wall claddings used in construction are made from absorptive materials.
- There is no such thing as a waterproof wall system; therefore, we must design a wall to control the amount of moisture allowed past the cladding.

Rainscreen works with a variety of cladding:

- Stucco
- Wood
- Manufactured Stone
- EIFS
- Thin Brick
- Natural Stone
- Fiber Cement
- Natural Brick

Use in geographical areas with:

- 20+ inches of rainfall annually
- High annual snowfall
- High wind volumes

How do we build a wall to the rainscreen standard?

Utilizing an engineered polymeric drainage and ventilation mat, or engineered batten/furring strip tested to ASTM E2925, along with a weather resistant barrier will allow builders to achieve a consistent capillary break within the wall to promote proper drying and draining. Refer to section R703.7.3.2 of the 2021 IRC.

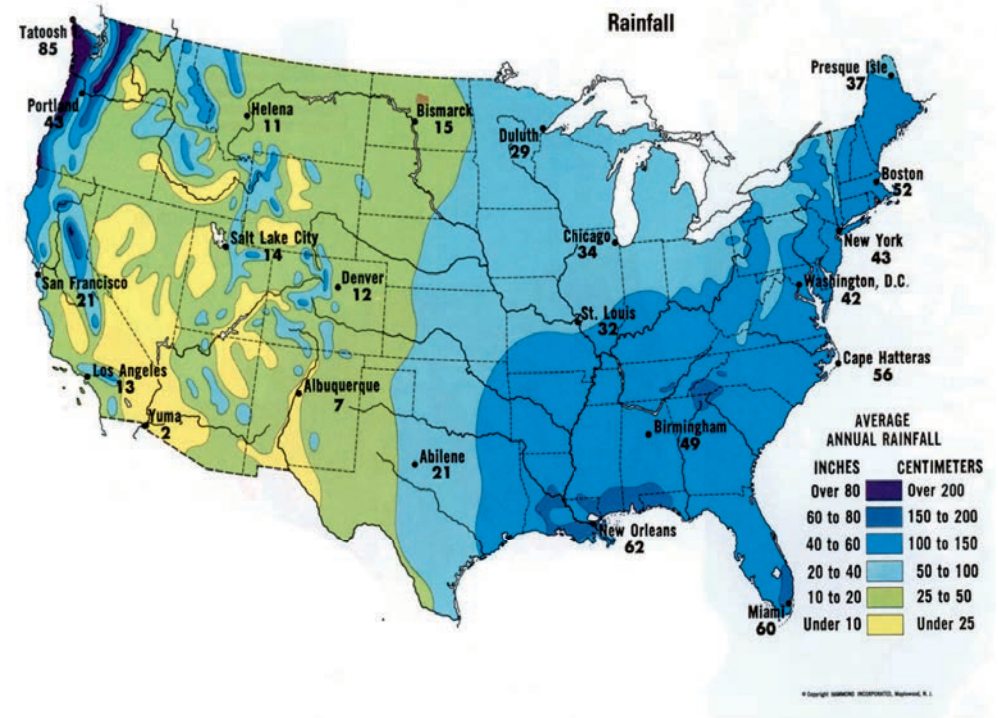



Additional Data



Benefits

- 95% open design creates a continuous capillary break and channel for moisture to drain and accelerates the drying of the exterior cladding.
- Durable polymer material is resistant to most known corrosive chemicals and does not provide a food source for mold or mildew.
- Minimizes staining, peeling, and blistering of exterior finishes.
- Lightweight and easy to handle.
- Easier and more cost effective than traditional wood furring strip methods.
- 2-ply design features a backer fabric that improves the tensile and compressive strength properties of the rainscreen. The fabric also serves to deflect mortar when used with stucco or masonry veneer siding.
- Made from recycled materials qualifying for LEED credits.
- Meets the National Building Code of Canada.
- Backed by our 25-year warranty.
- Tested to ASTM E2925 and **meets the 2021 & 2024 IRC Code requirement.**

Mortairvent[®] 202 (6mm)



Mortairvent[®] 203 (10mm)



Stucco Cladding

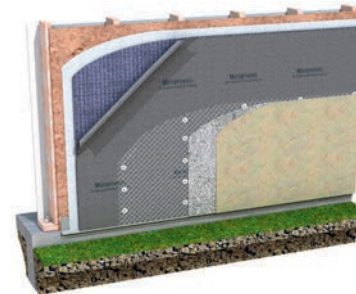

Panel Cladding System

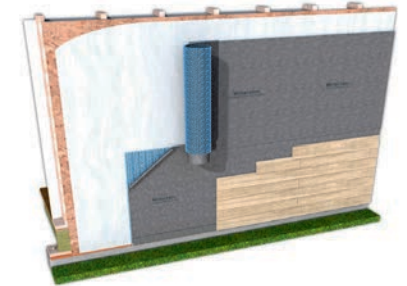

Manufactured Stone & Fiber Cement

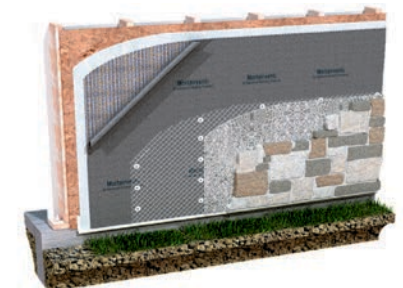

Packaging / Mortairvent[®] 201 (3mm)

39" X 61.5' (200 SF) roll
24 rolls per pallet

Mortairvent[®] 202 (6mm)

39" X 61.5' (200 SF) roll
18 rolls per pallet

Mortairvent[®] 203 (10mm)

39" X 40' (130 SF) roll
18 rolls per pallet

Mortairvent® Weep Screed & Veneer Vent®



Veneer Vent®

Veneer Vent® is designed to be used at the top and bottom of the wall for proper convective airflow evacuation in masonry veneer applications. In order for a rainscreen wall system to work effectively, there must be an intake and an exhaust. Veneer Vent® provides proper venting in wall systems that comply with the rainscreen wall recommendations as defined by the 2021 & 2024 IBC & IRC codes on plywood and OSB sheathing.

Packaging / 8' pieces - 20 pieces (160 LF) per box
20 boxes per pallet

Mortairvent® Weep Screed

Our pre-formed PVC weep screed flashing is used with masonry veneer or wood siding to facilitate moisture drainage. Located at the framed wall and foundation joint, the weep screed provides an egress for water that has penetrated the exterior finish, weeping from the walls by gravity to the screed. Made of exterior grade PVC, this design provides compliance with ASTM E2273 & E2925 for drainage and ventilation.

Packaging / 10' pieces - 35 pieces (350 LF) per box
20 boxes per pallet

Top Vent

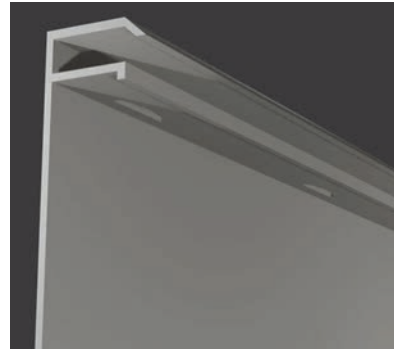

Bottom Vent

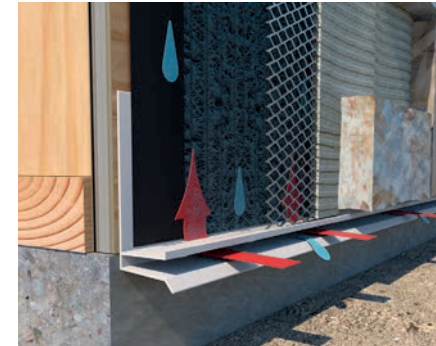
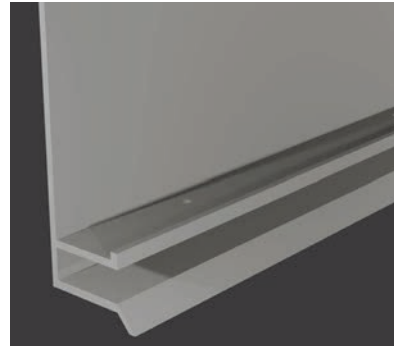

Mortairvent® Weep Screed & Veneer Vent® come in paintable white



Patent 2138.38A – US 10,914,077 | 2138.38-1 – CA 2983319



Additional Data



Installation Video

When building with clapboard siding, a wooden batten or furring strip is often used to create a capillary break. However, there are issues with the design and material used in wood furring strips:

- Wood is an absorptive material, which can lead to rotting and provides a food source for mold.
- The surface area of the wood furring strips covers a significant surface area of the wall, which creates opportunities for trapped moisture.
- The surface area contact between the furring strip and backside of the cladding can allow ghosting on the outside of the cladding and minimize cross ventilation.

The Watairvent® Furring Strip Advantage

Advanced Building Products has taken the traditional furring strip and redesigned it to function in today’s building environment.

The benefits include:

- Helps increase the longevity of wall sheathing and framing by allowing moisture to Drain, Not Remain™.
- Manufactured from a mold-resistant and non-absorptive composite material.
- Dual-channel design reduces surface area contact by 86% when compared to traditional wooden furring strips.
- Black in color with UV inhibitors used for open cladding applications.
- Will not become brittle and crack during cold weather installations.
- Lightweight and easy to install.
- Can also be used as a starter strip.
- Meets the National Building Code of Canada capillary break requirements for high-moisture index.
- Manufactured with fastening slots to allow differential movement during installation.
- Meets or exceeds applicable U.S. Building Codes.
- Tested to ASTM E2925.

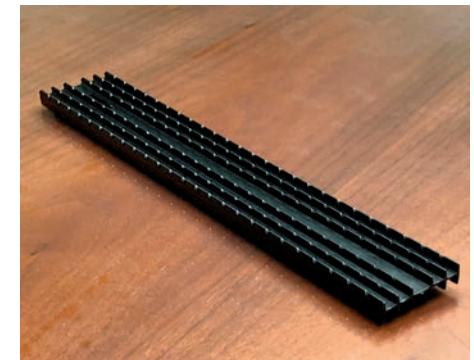

Packaging / 0.375" X 1.75" X 8' per piece
50 pieces (400 LF) per box
36 boxes per pallet

Core Design of Watairvent® Furring Strips

- Solid core for structural stability.
- Vertical channels for proper drainage and ventilation from the backside of the cladding to the front side of sheathing.
- Horizontal channels allow for cross ventilation.

Top of Wall Installation

- Watairvent® Furring Strip can be installed horizontally at the top of the wall, similar to the base of the wall. The furring strip will act as the bug screen and the airflow channels will remain free of debris.
- Leave a 0.75" gap between vertical and horizontal furring strips to allow for differential movement.

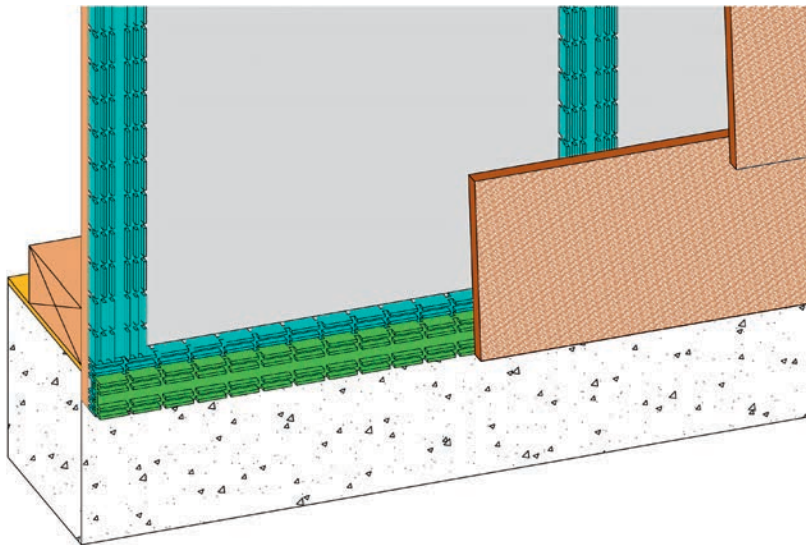
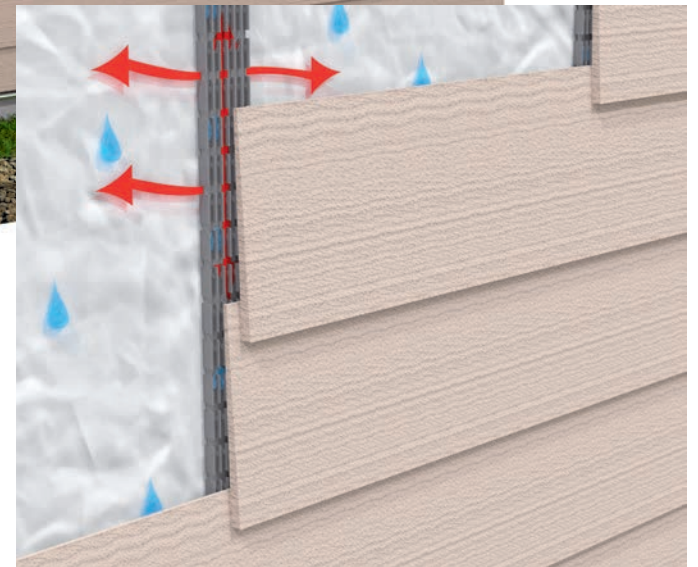
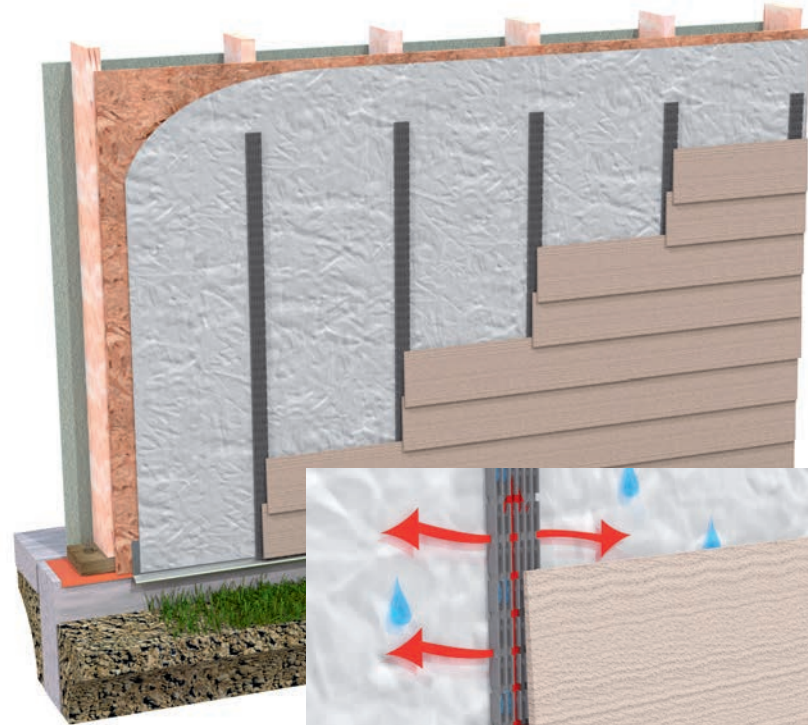



MORTAIRVENT® CW

Masonry Cavity Wall Drainage and Ventilation

Additional Data



Mortairvent® CW is our all-wall mortar deflection system for cavity wall construction that creates a clear drainage & ventilation space while maintaining the code minimum one-inch airspace. Our design gives specifiers and contractors more options from one manufacturing source.

Applications

For use as an all-wall mortar deflection. The gray filter fabric acts as a mortar diverter, which allows moisture, but not the mortar, to drain down the wall via the molded polymer core geomatrix design. With the proper installation of weep vents at all flashing locations, Mortairvent® CW will create an unobstructed clear path for moisture removal.

Features & Benefits

- The unique configuration provides uniformity and structural integrity which will stand up to the weight of the mortar.
- Mortairvent® CW, with the use of proper top and bottom vents, turns a drainage wall into a drained and ventilated rainscreen wall design.
- Will not rot or react with common building materials.
- Requires no adhesives, fasteners, or special skills to install.
- Meets NFPA 285 Criteria.
- 25-year warranty.

Packaging / Mortairvent® CW 206
0.80" X 16" x 50' per roll
20 rolls per pallet

Mortairvent® CW 206
0.80" x 39" x 50' per roll
8 rolls per pallet

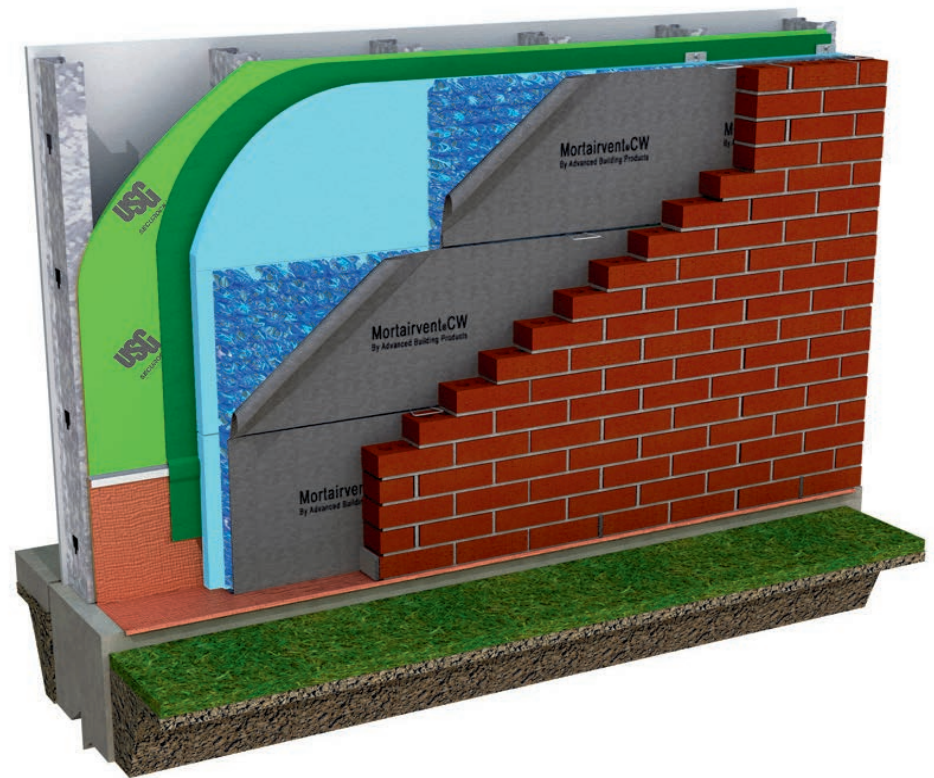



Mortar Break[®] DT is our widely specified multi-level mortar deflection system for cavity wall construction that breaks up mortar on multiple levels. Our design gives specifiers and contractors more options from one manufacturing source.

Applications

For use at all cavity wall flashing locations. The molded polymer core geomatrix design allows moisture to seep down through any mortar droppings and weep out of the wall through mortar-free weep vents.

Features & Benefits

The unique configuration provides uniformity and structural integrity which will stand up to the weight of the mortar.

- The multi-level design allows mortar droppings to break up on multiple levels allowing for proper drainage to the exterior of the wall system.
- Will not rot or react with common building materials.
- Requires no adhesives, fasteners, or special skills to install.
- Meets NFPA 285 Criteria.
- 25-year warranty.



Packaging / Mortar Break[®] DT 0.4"
10" X 5' - 250 LF per box
24 boxes per pallet

Mortar Break[®] DT 1.0"
10" x 5' - 100 LF per box
24 boxes per pallet

Mortar Break[®] DT 1.5"
10" x 5' - 100 LF per box
24 boxes per pallet

Mortar Break[®] DT 2.0"
10" x 5' - 100 LF per box
24 boxes per pallet



Mortar Break® and Mortar Break® II mortar deflection mats work in conjunction with masonry flashing and our weep vents as a complete and effective moisture management system. Both products suspend excess mortar droppings above the weep holes and allow any moisture trapped within the cavity to seep down the flashing and out of the wall. The system also helps to maintain an airspace for ventilation and drying of the wall cavity.

Mortar Break®

Designed to prevent mortar droppings from blocking drainage channels for 1" (25mm) masonry cavity wall applications.

Mortar Break® II

Designed to prevent mortar droppings from blocking drainage channels for 2" (50mm) masonry cavity wall applications.

Applications

For all cavity wall flashing locations including the base of the wall, above windows and doors, steel lintels, spandrels, and shelf angles, or at any other penetrations or obstructions.

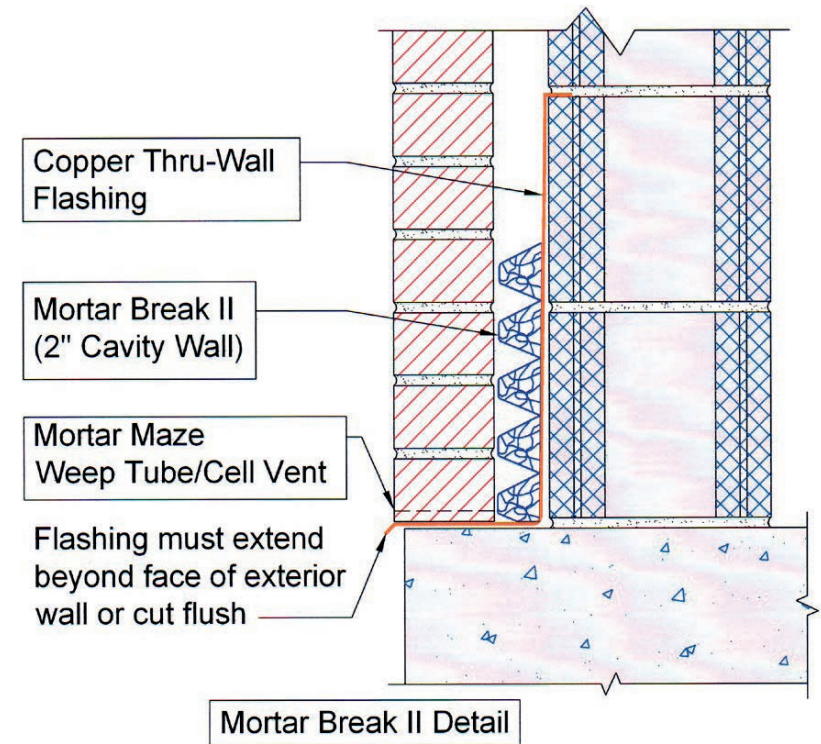
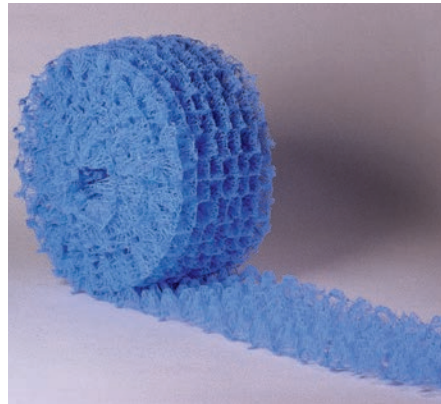

Packaging / Mortar Break®	Mortar Break® II
0.8" X 10" X 50'	1.6" x 10" x 35'
4 roll per box	4 rolls per box
8 boxes per pallet	8 boxes per pallet



Mortar Catch® is designed for use at all flashing locations where wide cavity (greater than 2 inches) construction is required. The open mesh geomatrix design, when shaped in a “U” configuration, fills the entire cavity to prevent mortar droppings from blocking the base wall and head joint drainage channels. This allows moisture within the cavity to seep down the flashing and out of the wall.

Benefits

- Deflects mortar droppings, allowing moisture to drain.
- Greater airflow and drainage compared to most plastic mesh-based products.
- Lightweight & easy to install with no mechanical fastening.

Mortar Maze® Weep Vents

Mortar Maze® Weep Vents ensure positive drainage in all cavity wall construction, while also restricting insects and other debris from entering the head joint. Made from durable polypropylene, Mortar Maze® Weep Vents are available in a range of colors to match the surrounding mortar. Polypropylene tested in conformance with ASTM D2240, D790B, D638, and D1238B.

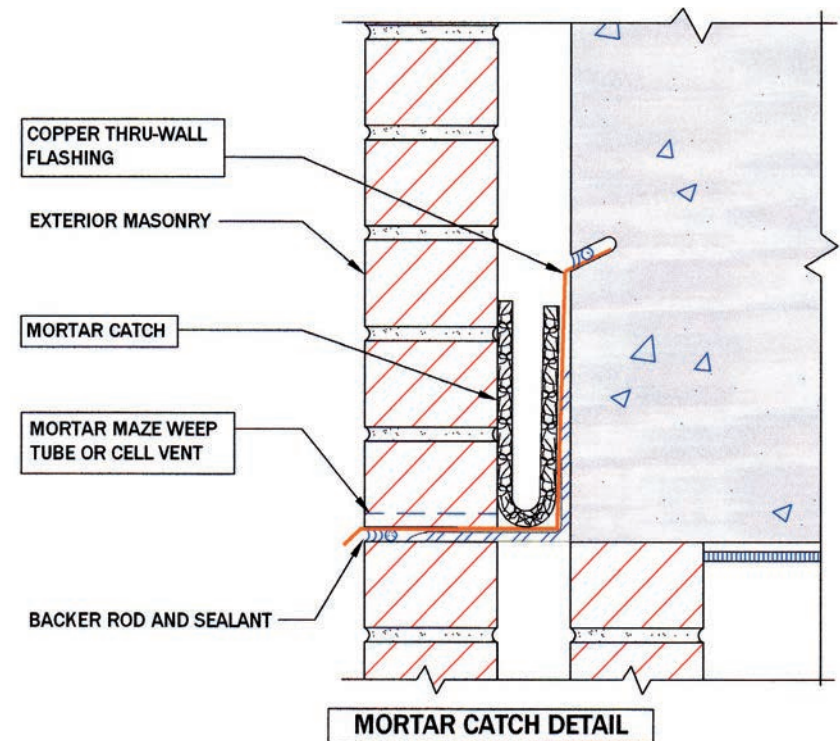
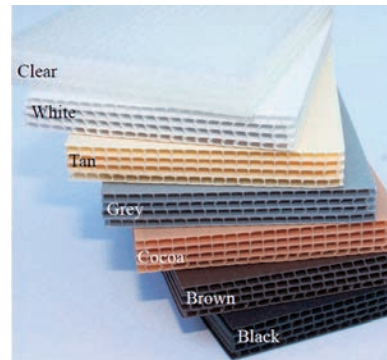

Packaging / Standard Weep Vents

0.375" X 2.5" X 3-3/8"
200 pcs. per box

Jumbo Weep Vents

0.375" x 3.5" x 3.5"
200 pcs. per box

Mortar Catch®

0.4" X 10" X 100'
4 rolls per box
8 boxes per pallet

Mortar Catch®

0.4" X 20" X 100'
2 rolls per box
8 boxes per pallet

Mortar Catch®

0.4" X 39" X 100'
1 roll per box
8 boxes per pallet



R-Vent® is a roof ventilation mat designed to create an airspace to promote multi-directional air flow between the roofing material and the sheathing below. R-Vent® prolongs the life of the roof structure and membrane by reducing the adverse effects associated with water damage including mold, mildew, or corrosion and deterioration of the roofing material itself. R-Vent® is perfect for residential and commercial applications.

Benefits

- Creates an open structure for heat reduction and ventilation.
- Reduces moisture's ability to remain trapped between the sheathing and underside of the metal roof panel.
- Prolongs the life of the roofing membrane & sheathing.
- Reduces sound transmission through the metal panels.
- Lightweight & easy to install.
- Bends and conforms to any type of contoured surface.
- Maintains thermal break.
- UV exposure of 60 days.
- Manufactured from Nylon 6.
- 25-year warranty.

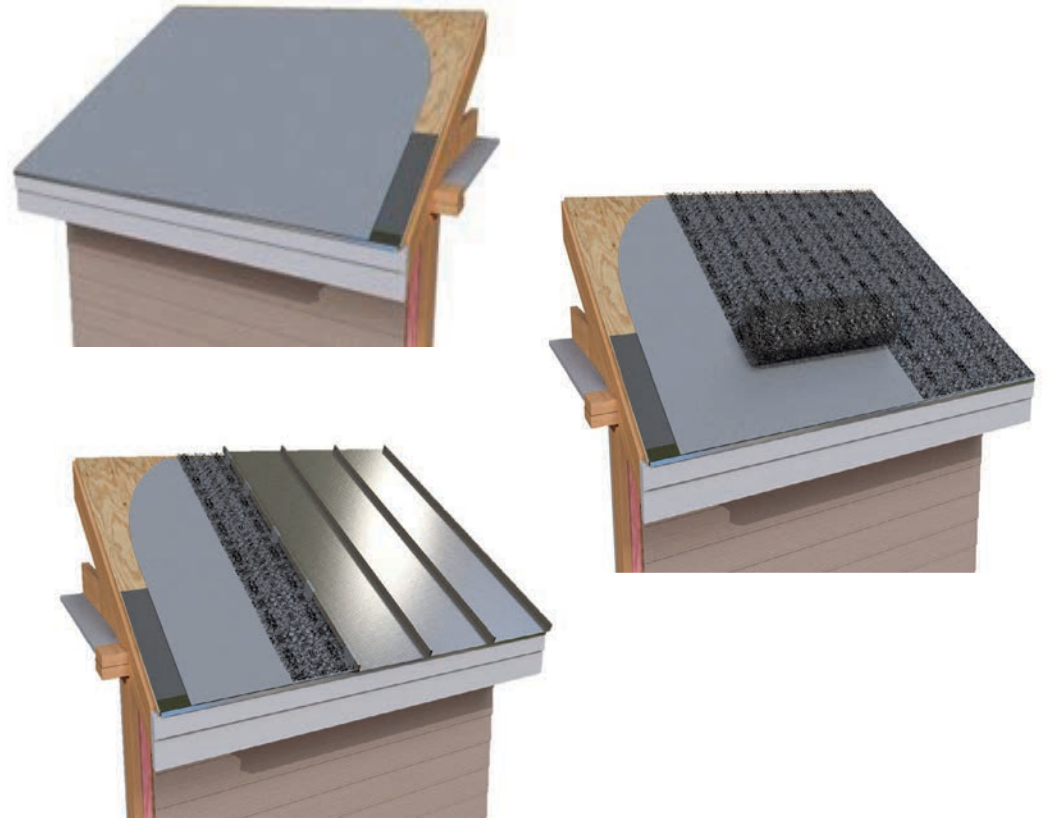

Packaging / 0.361" X 39" X 61.5' (200 SF) roll
18 rolls per pallet

Why R-Vent®?

Condensation of Water Vapor

- Water vapor from a humid interior moves through the attic and permeable roof materials.
- With a permeable WRB, vapor can pass but can condense under the cold metal roof.
- Moisture needs a way to drain & dry out.
- A 3D drainage and ventilation mat between the metal and roofing felt drains and dries the condensation.
- R-Vent® creates the capillary break needed for the moisture to Drain, Not Remain™ trapped on the underside of the metal panels.

Drying of Condensation

- Air movement through R-Vent® dries any remaining moisture.
- R-Vent® under roof panels completely supports the metal.
- Provides a slight bow and tension to minimize the oil canning appearance.
- Uniform “pillowing” of panel.
- Done by using clips $\frac{1}{8}$ -inch shorter than mat thickness (i.e. $\frac{1}{4}$ -inch clip over $\frac{3}{8}$ -inch mat).

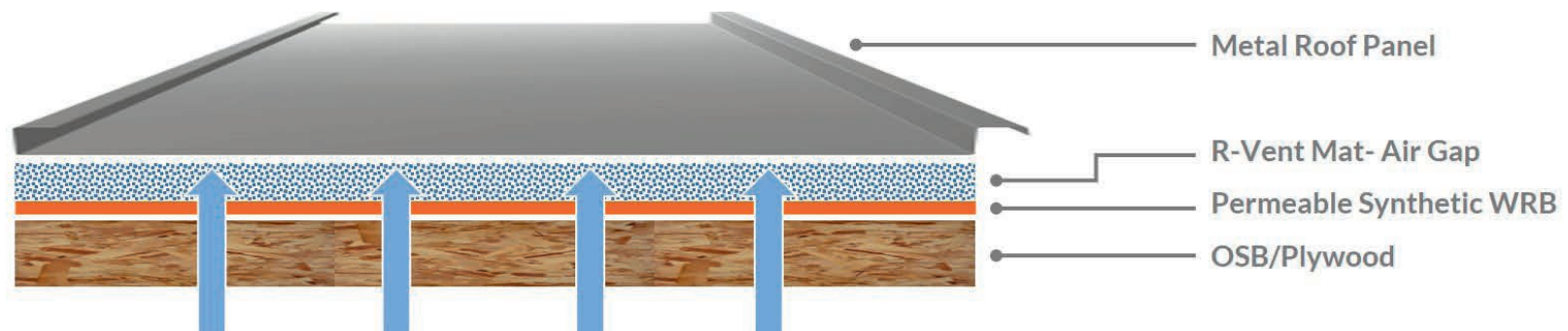
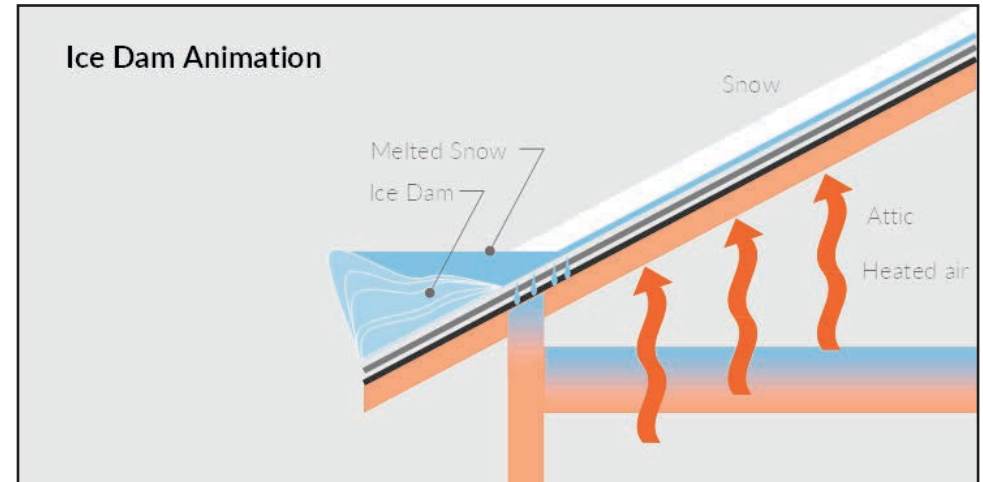



CedAir-Mat® is a roof ventilation mat designed to create an airspace to promote multi-directional airflow between wood roofing material and the sheathing below. Using a thin nylon matrix profile, CedAir-Mat® prolongs the life of the roof structure and membrane by reducing the adverse effects associated with water damage including mold, mildew, or corrosion and deterioration of the roofing material itself. CedAir-Mat® is perfect for residential and commercial applications.

Benefits

- Creates an open structure for ventilation.
- Prolongs the life of roofing membrane & sheathing.
- Reduces sound transmission.
- Lightweight & easy to install.
- Bends and conforms to any type of contoured surface.
- Maintains a thermal break.
- UV exposure of 60 days.
- 75% greater air flow compared to alternative products.



Packaging / 0.407" X 39" X 61.5' (200 SF) roll
12 rolls per pallet

CedAir-Mat® Installation

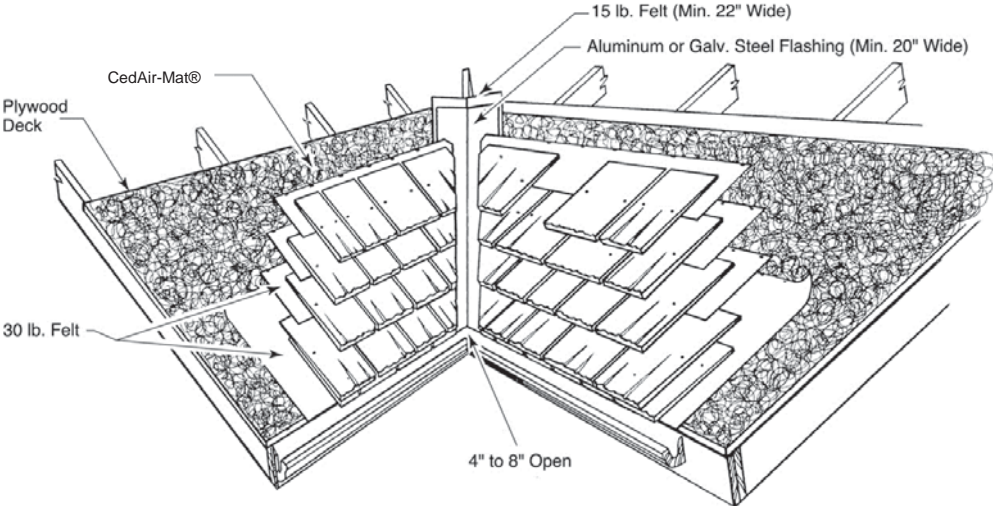
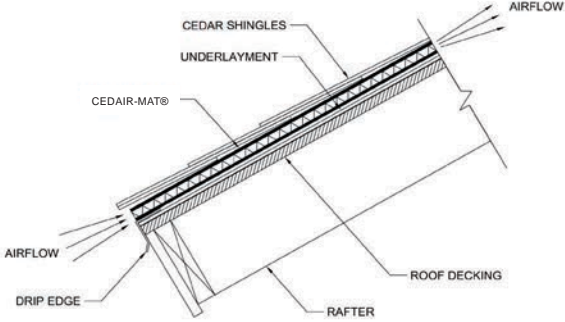
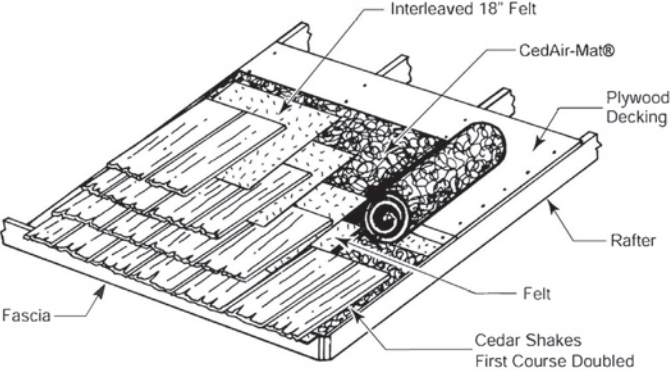
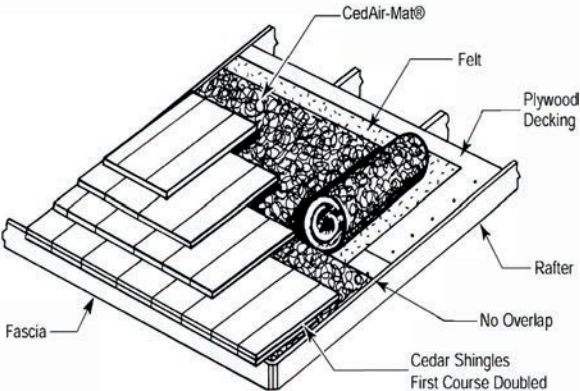



Additional Data



The Ground Guard® Root Reinforcement Mat provides an effective and eco-friendly choice for securing plant roots in all types of erosion prone areas. The tough, black nylon mesh has an open structure which makes a perfect environment for dirt and plants to embed and entangle, permanently securing plant roots in place. Once the root system is established, you have a permanent solution for anchoring vegetation. The Ground Guard® Root Reinforcement Mat is a natural choice for vegetated roof applications requiring soil and root stability.

Applications

- Channels & slopes
- Green roofs/roof gardens
- Sloped or irregular shaped roofs
- High-wind environments
- Eco-habitats

Benefits

- Permanently secures plant roots.
- Enhances plant growth and survival.
- Lightweight and easy to handle.
- Open structure is easy to soil fill.
- Dimensionally stable in warm or cold weather.

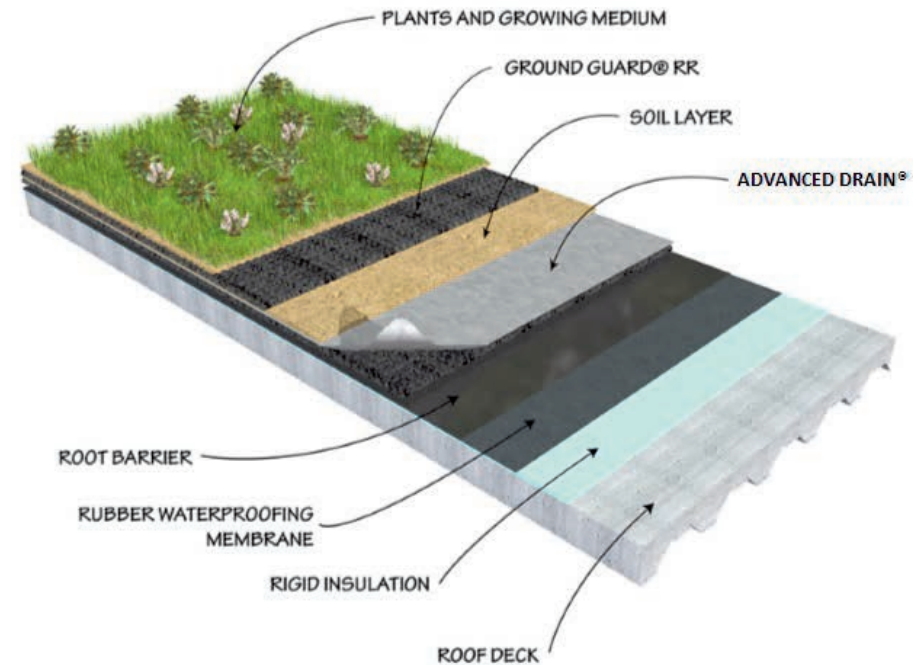

Packaging / 0.40" X 39" X 100' (325 SF) roll
8 rolls per pallet



Installation Video



Ground Guard® VM is an eco-friendly growing mat designed for use with pre-vegetated systems requiring extra soil and root stability. Once the root system is established, you have a permanent solution for anchoring vegetation to facilitate transport and installation.

Benefits

- Plants can be grown directly in matting or field-grown off-site in matting.
- Permanently secures plant roots.
- Enhances plant growth and survival.
- Easy to install vertically or horizontally.
- Filter fabric helps hold soil in place.



Packaging / .625" X 39" X 100' (325 SF) roll
8 rolls per pallet



AdvancedDrain® is our multi-purpose polymer matrix that serves as a high-quality drainage and ventilation mat in several applications. Available in 1/8", 1/4", and 3/8" thickness, these drainage composite mats are produced from an extruded polymer matrix into parallel channels and are backed with a non-woven filter fabric that is heat-bonded to one or two sides of the entangled monofilaments, depending on the application. This prevents soil from entering the matrix of the system. AdvancedDrain® is designed to eliminate hydrostatic pressure and allow ample air and moisture flow in all directions, reducing any potentially damaging moisture buildup.

Features & Benefits

- Filtration and drainage in one package.
- Lightweight & easy to install in either vertical or horizontal directions with either construction adhesive or termination bar.
- Sufficient fabric overlap for sealing adjacent panels with construction adhesive to prevent soil intrusion at the joints.
- Polymer core resistant to most known solvents and chemicals including acids and bases.

Applications

- Residential and commercial foundation walls
- Retaining walls
- Planters
- Plaza decks, walls, and balconies
- Green roofs

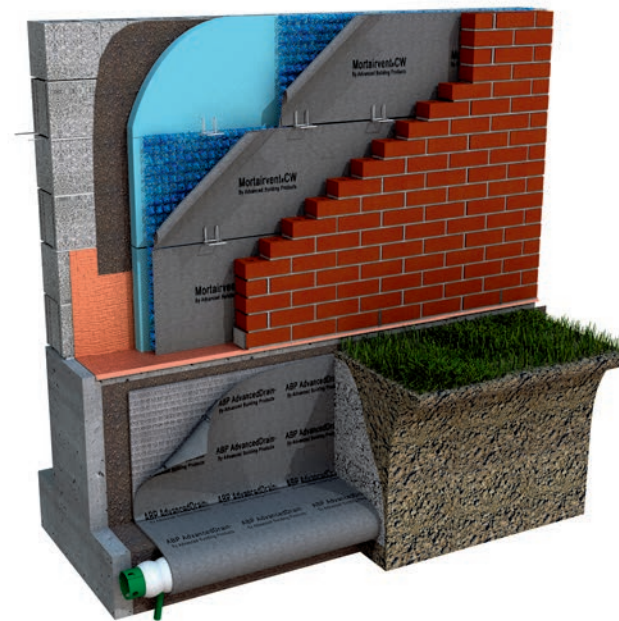
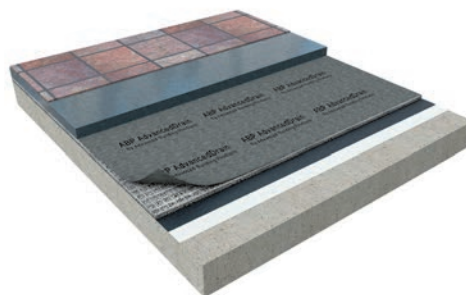

Packaging /	0.125" X 39.5" X 150'	0.250" X 39.5" X 135'	0.400" X 39.5" X 100'
	10 rolls per pallet	8 rolls per pallet	8 rolls per pallet



Additional Data



RAM Vent™ is a lightweight entangled geomatrix manufactured for use in an active radon mitigation system. RAM Vent™ is manufactured with a heat-bonded filter fabric on one or two sides allowing air to flow freely based on our 95% open entangled design.

Benefits

- RAM Vent™ has a high compressive strength.
- Made from polypropylene, the filaments resist most chemicals and solvents.
- Our high air flow system reduces the level of radon by up to 97% when used with proper piping and exhaust fan system.
- The 95% open air space gives a much higher airflow rating when compared to aggregate.

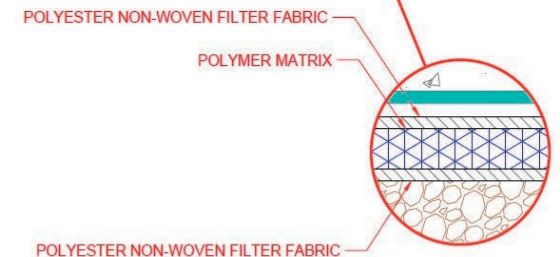
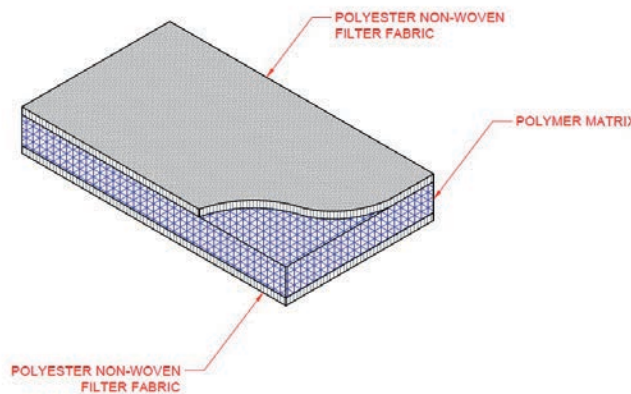
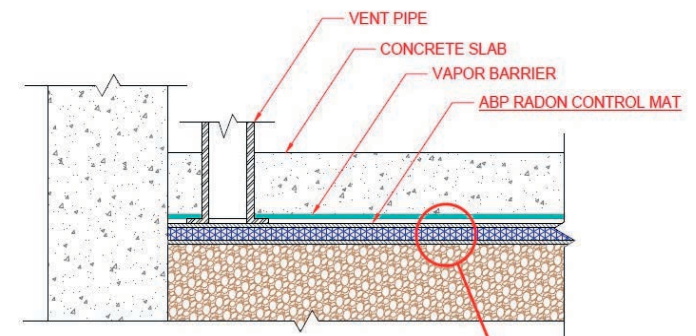
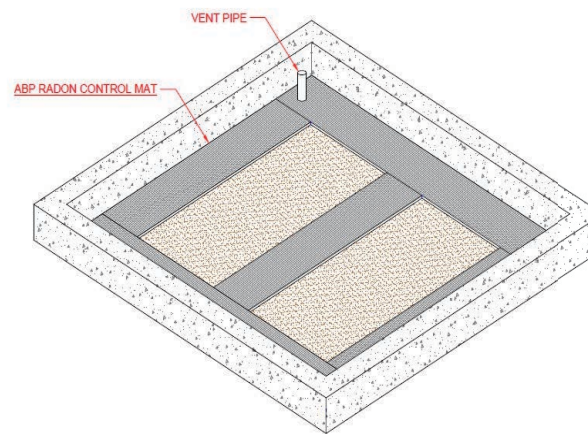

Packaging / 0.80" X 20" X 50'
16 rolls per pallet

*Other sizes available upon request.



*US Patent # 12,345,437



COMING
SOON

Installation Video



Insulair® creates a continuous 90% open air space between the roof deck and the spray foam insulation or between the roof deck and batt or spray foam in cathedral ceiling applications. Insulair® dries and vents the air preventing deterioration to the wood sheathing from condensation moisture common in these applications. Insulair® is applied to the interior side of the roof assemblies in residential and light commercial construction. The product has an open filament waffle core designed with filter fabric on the interior side to assure a clear vented path free of insulation intrusion. Insulair® is made with polymers that are stable and do not deteriorate when in contact with moisture.

Recommended Applications

- For new construction with spray foam insulation under the roof deck.
- For retrofit of existing attic & roof deck with spray foam insulation.
- For new construction or renovation of cathedral ceiling systems.

Benefits

- Promotes drying in the roof assembly.
- Easy to install.
- Able to withstand extreme temperatures.
- Recycled content for LEED points.
- Cuts with a utility knife or scissors.
- Creates a continuous vent from soffit to ridge.



How Insulair® Works

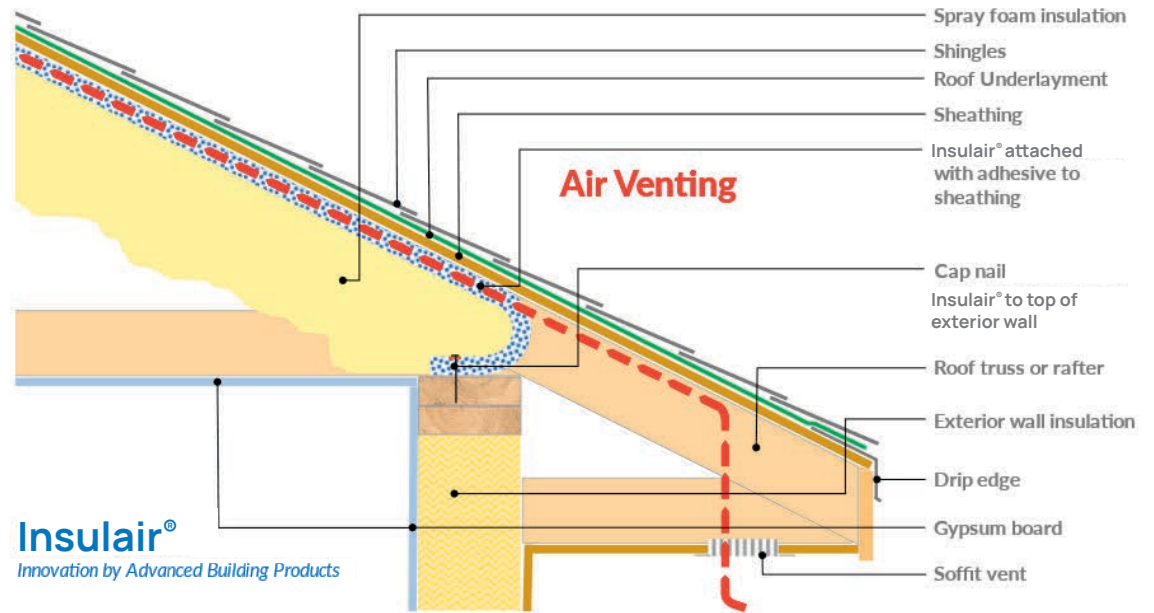

Net Free Area* How much?

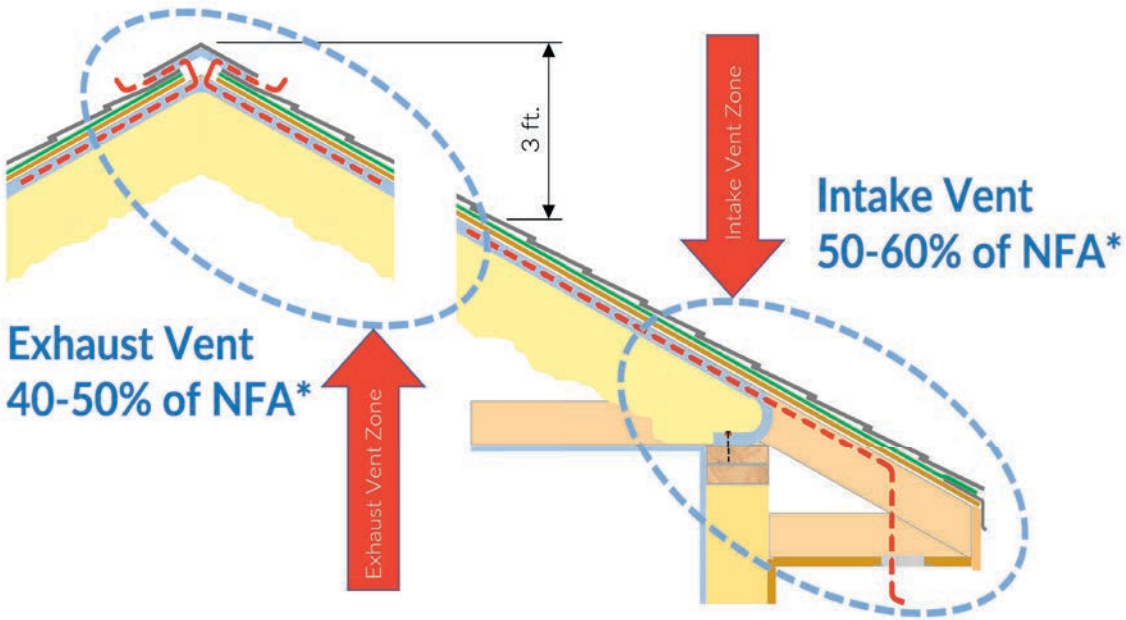

INDUSTRY AFFILIATIONS & MEMBERSHIPS

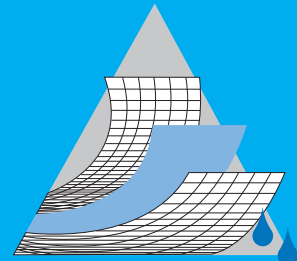

ADVANCED
Building Products Inc.

95 Cyro Drive, Sanford, ME 04073
P / (800) 252-2306 F / (207) 490-2998
AdvancedBuildingProducts.com

